

Stichting Theaters Tilburg  
Technical Specifications  
Schouwburg



# Table of Contents

General Information .....	3
Accessibility .....	4
Technical general information.....	5
Dimensions .....	7
Orchestra facilities.....	8
Fly system .....	9
Electrics and infrastructure .....	11
Lighting .....	12
Audio .....	14
Video.....	15
Hospitality and facilities.....	16





## General Information

### Adress

City	Tilburg
Theater Hall	Schouwburg Concertzaal Tilburg Schouwburg
Visiting Address & Parking Performers entrance	Louis Bouwmeesterplein 1 5038 TN Tilburg <a href="#">Location Performers entrance</a>
Loading Dock Lift 1	Louis Bouwmeesterplein, Tilburg <a href="#">Location Trailerlift 1</a>
Lift 2	Kloosterstraat 6-2, Tilburg <a href="#">Location Trailerlift 2</a>

### Contact information

Technical department	+31 013 5490 390 <a href="mailto:techniek@schouwburgconcertzaaltilburg.nl">techniek@schouwburgconcertzaaltilburg.nl</a>
General	+31 013 5490 390 <a href="mailto:info@schouwburgconcertzaaltilburg.nl">info@schouwburgconcertzaaltilburg.nl</a>
Contact Production + Hospitality	+31 013 5490 390 <a href="mailto:programma@schouwburgconcertzaaltilburg.nl">programma@schouwburgconcertzaaltilburg.nl</a>
Ticketservice	+31 013 5432 220 <a href="mailto:ticketservice@schouwburgconcertzaaltilburg.nl">ticketservice@schouwburgconcertzaaltilburg.nl</a>

### Standard times

Lunch	12:30 – 13:00
Dinner	17:00 – 19:00
Evening showtime	20:15
Showtime matinee	variable

### Merchandise

Schouwburg Concertzaal Tilburg does not charge a fee for merchandise. A suitable location will be determined on the day itself in consultation with the management representative. We can provide power and light at the chosen location.

## Accessibility

The main entrances of the Schouwburg, Concertzaal and Studio are located on the Schouwburgring. The coordinating address and the backstage entrance is Louis Bouwmeesterplein 1, 5038 TN Tilburg.

In the centre of Tilburg (within the ring roads), there is an environmental zone. This area is not accessible to diesel trucks with emission class 0 to 5.

For more information and to apply for an exemption, visit the website of the Municipality of Tilburg:

[Ontheffing milieuzone - Gemeente Tilburg](#)

## Parking

At Schouwburg & Concertzaal Tilburg, we have a limited number of parking spaces available. These are allocated on the day itself in consultation with the porter. Unfortunately, it is not possible to reserve parking spaces in advance. However, it is always possible to park at the nearby "[Schouwburg](#)" parking garage. Parking there is at your own expense and subject to the regular rates. We do not provide exit tickets for this garage.

Please consider that Thursday evenings are extra busy due to extended opening hours of stores in the city centre. Parking takes considerably more time than on other days. Extra crowds can also be expected on Sundays and holidays.

## Public transport

Tilburg Central station is located at 15 minutes walking distance from the theatre. It also an option to take a city taxi or a bus.

## Loading dock

To be able to load and unload trucks, two elevators are used to lift trucks up to stage level.

Max. length trucks: 18m

At its smallest, the passage to the stage is 3m wide and 6m high

[Location lift 1](#)

[Location lift 2](#)

# Technical general information



## Venue capacity

<b>Total</b>	860
<b>Floor level, incl. orchestra pit</b>	544
<b>orchestra pit</b>	39
<b>1<sup>e</sup> Balcony</b>	169
<b>2<sup>e</sup> Balcony</b>	164
<b>Standard amount of FOH places</b>	12 (2x6) <i>Other numbers in consultation</i>

## Soft furnishings and details

<b>Stage floor</b>	Material	Keroewing Hardwood
	Thickness	28mm - 500 kg/m <sup>2</sup>
<b>Marley</b>	Colour	black
	Width	1.60m per lane
<b>House curtain</b>	Colour	Red/green
	Operation	Stage Left, manual
	Way of Opening	Traveler

## Soft goods and masking

General		Colour	Night Blue	
12x	leg	Height	10.00	meter
		Width	05.50	meter
5x	border	Height	04.00	meter
		Width	21.00	meter
1x	border	Height	06.00	meter
		Width	21.00	meter
3x	full black	Height	10.00	meter
		<i>Consists out of 12 extra legs</i> Width	20.00	meter
2x	side blacks	Height	09.00	meter
		<i>Consists out of 6 short legs</i> Width	13.50	meter
2x	side blacks	Height	09.00	meter
		<i>Consists out of 4 pieces on a rails, attached permanently</i> Width	02.00	meter
1x	Cyclorama	Height	10.00	meter
		Width	21.00	meter
1x	Black gauze	Height	10.00	meter
		Width	18.00	meter
1x	Opera foil	Height	08.00	meter
		Width	16.00	meter
1x	full black (black)	Height	10.00	meter
		Width	19.00	meter

## Dimensions

### Stage dimensions

<b>Proscenium</b>	Height	08.70	meter
	Width	13.70	meter
<b>Portal</b>	Height	Min.	00.00 meter
		Max.	08.15 meter
	Width	Min.	10.00 meter
		Max.	15.80 meter
<b>Stage floor</b>	Width	21.00	meter
	<i>Including wing space</i>	34.00	meter
<b>Zero to rear wall</b>	Depth	12.00	meter
<b>Edge of the apron to rear wall</b>	Depth	15.00	meter
<b>Edge of the orchestra pit to rear wall</b>	Depth	18.00	meter

### Distances from zero

<b>Edge of the apron</b>	-03.00	meter
<b>Rear wall</b>	14.70	meter
<b>Backwall auditorium</b>	-19.60	meter
<b>House curtain</b>	-01.51	meter
<b>Proscenium fly bar</b>	-01.26	meter
<b>Portal</b>	-0.79	meter
<b>Backside safety curtain</b>	-1.78	meter

### Heights relative to stage floor

<b>Fly loft</b>	20.70	meter
<b>Maximum fly bar height</b>	19.70	meter
<b>Side bridges</b>	Min.	1.00 meter
	Max.	12.00 meter

### Maximum dimensions for merchandise flight cases

78 x 138 x 155 (LxWxH, in cm)

## Orchestra facilities

### Orchestra pit

The orchestra pit is variable in height between the orchestra pit level and the stage. The pit exists out of a fixed room beneath the stage and a moving part in the auditorium

The orchestra pit is accessible via 2 doors, left and right through normal sized doors and a small set of stairs. Instruments can be brought to the orchestra pit from ground level and stage level.

For the dimensions of the orchestra pit, see the floorplan on the website.

### Orchestra facilities

<b>Conductor riser</b>	1x	100 x 100 cm, variable height, including conductor stand
<b>Orchestra chairs</b>	55x	Without armrests
<b>Music stands</b>	45x	Adjustable height
<b>Reading lights</b>	45x	For music stands

### Risers

<b>Risers</b>	40x	200x100 cm
	2x	100x100 cm
<b>Legs</b>	60x	20 cm (15 risers)
	60x	40 cm (15 risers)
	48x	60 cm (12 risers)
	36x	80 cm (9 risers)
	36x	100 cm (9 risers)
<b>Stairs</b>	2x	20, 40, 60 and 80 cm
<b>Masking</b>		20, 40, 60, 80 and 100 cm
<b>Fall prevention</b>		Multiple lengths and amounts
<b>Fences</b>	14x	95 cm high, 200 cm wide
	10x	95 cm high, 100 cm wide

### Grand Piano

<b>Grand Piano</b>	Steinway B	Serial nr. 524797
<b>Piano</b>	Seiler	Serial nr. 160630

The grand piano is always available, piano only upon request.

## Fly system

The fly system is computer controlled with a TNM system by the manufacturer Trekwerk. All flybars except the flybars in the auditorium and 2 flybars underneath the side bridges are connected to this system. The loading capacity of the system is assessed according to the NPR8020-10 with a safety factor of 10 (hoists above persons)

The SWL/WLL on all lifting materials must therefore be halved. All hoisting equipment of Schouwburg Concertzaal Tilburg is rated with a factor 10. Rigging and hanging of loads is only permitted with certified equipment. Such is all at the discretion of the on duty fly bar operator of Schouwburg Concertzaal Tilburg.

The fly system can only be be controlled by a qualified operator from Schouwburg Concertzaal Tilburg.

## Fly bars

59 fly bars

Max. Height 19.70 meter

Min. Height 00.05 meter

Fly bar length 21.00 meter

Max. Speed 1.7 m/s

Distance between fly bars 20 cm (with the exception of fly bars 02, 20, 38, 56, due to steel beams 30-35 cm distance)

Distance between zero to 1<sup>st</sup> fly bar is 00.38 meter.

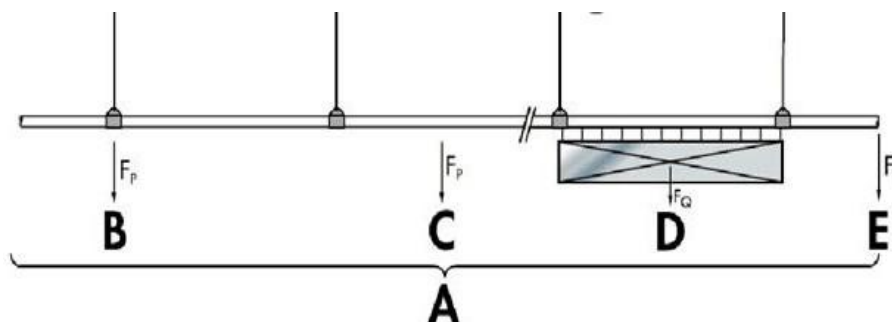

Max. load, see below.

	A	B	C	D	E
Fly bars	500 kg	250 kg	250kg	300Kg	75 kg
Proscenium fly bar	500 kg	250 kg	250kg	300Kg	75 kg
Side fly bars	500 kg	250 kg	250kg	300Kg	75 kg

## Side fly bars

6 side fly bars;  
2 on the inside of the side bridges, fly bar length 12.50m;  
2 on the outside of the side bridges, fly bar length 11.50m; max. load see table above.  
2 side bars underneath side bridges, not controlled by the fly system. Max. load is 300 kg

## Proscenium fly bar

Flybar length 19.00 meter  
Max. speed 1.7 m/s  
Distance to zero -01.26 meter  
Max. load see table above

## Auditorium fly bars

The auditorium flybars are mainly used for audio rigging.  
1 left, fly bar length 2m, max load 500 kg  
1 centre, fly bar length 2m, max load 300 kg  
1 right, fly bar length 2m, max load 500 kg

There is also 1 fly bar located underneath the first FOH bridge.  
Max. load is 300kg with equal load, 150kg point load.

## Point hoists

12 point hoists (chain hoists)  
4 areas which can all contain a maximum of 3 hoists.  
Max. load is 500kg  
Max. height is 20m  
Min. height 0m

## Electrics and infrastructure

### Power distribution

All high voltage current connections have CEE-norm red connectors, with 3 phases, zero and ground

<b>125A</b>	1x	Stage left, downstage
	1x	Stage right, downstage
	1x	Stage right, centre stage
<b>63A</b>	2x	Stage right, centre stage
<b>32A</b>	2x	Stage right, centre stage
	1x	Stage right, down stage (audio)
	1x	Stage left, centre stage (16 A fuse)
	1x	Stage left, downstage (audio)
	1x	Side bridge stage right
	1x	Side bridge stage left
<b>220V 16A</b>		Multiple points, CEE and wall sockets

### DMX

The DMX- network is installed as a star-network, of which the middle is located at stage left, downstage. DMX can be sent and received at multiple locations throughout the venue.

### Network

The venue also has an extensive CAT7 network. Multiple lines for audio, video and sACN are located throughout the venue.

# Lighting

## LED conversion

The LED fixtures in the 2<sup>nd</sup> FOH and in the proscenium can be controlled with one channel. For the Cyclorama 4 colours are available. Each light can be programmed with any colour desired by the visiting company.

If desired, it is also possible to control the LED fixtures in their full mode with sACN.

For a current patch list, contact our technical department at [techniek@schouwburgconcertzaaltilburg.nl](mailto:techniek@schouwburgconcertzaaltilburg.nl)

## Lighting console

GrandMA3 Compact XT (from September 2026)

### Prerigged fixtures

<b>1<sup>st</sup> FOH</b>	20x	Altman 2kW zoomprofile
<b>2<sup>nd</sup> FOH</b>	12x	ETC Source4 LED Tungsten HD 14°
<b>Portal</b>	12x	Altman 1kW zoomprofile 12°-40°
	8x	ADB C101 1kW PC
<b>Side bridges (per side)</b>	10x	Altman 2kW zoomprofile 12°-40°
<b>Proscenium (per side)</b>	3x	ETC Source4 LED Tungsten HD 15°-30°
<b>Side of the portal (per side)</b>	6x	Altman 1kW zoomprofile 12°-40°
<b>Cyclorama</b>	14x	Robert Juliat Dalis 860
<b>Follow spot</b>	2x	Robert Juliat Victor 1800W MSR
<b>House lights</b>		Led fixture, divided in 3 groups
<b>Curtain warmers</b>	4x	ADB C51 500W PC, from 1 <sup>st</sup> FOH
<b>Conductor lights</b>	2x	Altman 2kW zoomprofile, from proscenium (fixed position)
<b>Orientation lights</b>		Stage Left, Stage Right and upstage

## Extra fixtures

<b>Pars</b>	24x	ETC Source4 MultiPAR 750W; WFL, MFL, NSP, VNSP
	6x	6-bar ETC Source4 MultiPAR 750W; WFL, MFL, NSP, VNSP
<b>PC</b>	16x	ADB 1kW C103 met barndoors
	16x	ADB 2kW C201 met barndoors
<b>Zoom profile</b>	16x	Altman 1kW zoomprofile 12°-40°
<b>Fresnell</b>	8x	Desisti 2kW Leonardo
<b>Flood</b>	8x	Floodlight
<i>In consultation with other halls</i>		
<b>LED profile</b>	12x	ETC Source4 LED Lustr+ 25°-50°
<b>LED strip</b>	12x	Showtec Pixelbar 18 Q4
<b>Movingheads</b>		
<b>Spot</b>	6x	GLP Impression S350 profile
<b>Wash</b>	8x	Clay Paky K10 B-Eye
	12x	Prolights Astra Wash 7Pix

## Hazer

Schouwburg Concertzaal Tilburg owns 1 MDG ATMe  
The use of this is free of charge, if available.

Fire alarms can be turned off, but always in consultation with the technicians of Schouwburg Concertzaal Tilburg

# Audio

## System

<b>Main</b>	Meyer M'elody; auditorium fly bars stage left and right Meyer CQ1 en 600-HP; apron left and right
<b>Center</b>	Meyer UPA; centre auditorium fly bar
<b>Infill</b>	Meyer UPM-2P; stage left and right Meyer UPM-2P; front fill on the apron stage left and right
<b>DSP</b>	Galileo 616 processor

## Monitors

<b>Monitors</b>	4x	D&B MAX12
<b>Amplifiers</b>	2x	D&B D6 Amplifiers

## Multi-cable

<b>Analog</b>	36 ch.	Harting HAN108 audio FOH position auditorium 36x XLR Stage left and right 36x XLR in the control booth
<b>Digital</b>	Cat7	Ethernet Cat7 connection, assigned to D-rack

## Consoles

<b>Console</b>	Yamaha DM7(C)	The use of our consoles is always in consultation and depends on the availability in our other halls.
<b>Rack</b>	Rio D3	Located on stage right

## Extra material

Schouwburg Concertzaal Tilburg has, in addition to the standard systems in our halls, an extensive collection of consoles, mics, wireless transmitters, monitors and other supplies and cables. These can be used in consultation with our other halls. For information and availability reach out to our technical department, via [techniek@schouwburgconcertzaaltilburg.nl](mailto:techniek@schouwburgconcertzaaltilburg.nl)

## Backline

Schouwburg & Concertzaal Tilburg does not own any backline.

## Volume restrictions

Schouwburg & Concertzaal Tilburg enforces a limit of 103Db(a) measured over 15 minutes at FOH.

## Video

Schouwburg Concertzaal Tilburg has multiple audiovisual supplies, which contain beamers, laptops and mixing devices.

Availability is always in consultation with our other halls.

For information and availability reach out to our technical department, via

[techniek@schouwburgconcertzaaltilburg.nl](mailto:techniek@schouwburgconcertzaaltilburg.nl)



## Hospitality and facilities

### Dressing rooms

<b>Stage level</b>	5x	Ladies and men's toilets, connection for 3 washing machines and dryers, elevator to ground level <b>Dressing room 3</b> 2-4 persons, adapted disabled toilet <b>Dressing room 4, 5 and 6</b> 2-4 persons, shower, sink <b>Dressing room 7</b> 6-10 persons, sink
<b>Ground level</b>	2x	2 dressing rooms, Ladies and men's toilets, 4 showers <b>Dressing room 10</b> 12-25 persons, sinks <b>Dressingroom 11</b> 12-25 persons, sinks

An audio feed of the auditorium and public address system are available from stage left and control booth.

### Green room

Shared with the Studio.

Space for 50 persons, seating for 36 persons.

Analog tv feed, monitor with feed from the stage.

Small audio installation, mic available

An audio feed of the auditorium and public address system are available from stage left and control booth.

There is someone from our hospitality department available in the green room from the moment the artists arrive, until after intermission. Other times are in consultation with our hospitality department.

### Laundry facilities

Schouwburg & Concertzaal Tilburg does **not** own any washers or dryers that can be used. We do have multiple connections for washers and dryers in the hallway of the stage level dressing rooms.

### Wi-Fi

Schouwburg & Concertzaal Tilburg has free Wi-Fi for artists. This network is password protected. The password

### Catering

Schouwburg & Concertzaal Tilburg can provide catering services. For more information, please contact [programma@schouwburgconcertzaaltilburg.nl](mailto:programma@schouwburgconcertzaaltilburg.nl) well in advance.